

MaxiLED
Lighting



MaxiGOBO QUAD

MaxiGOBO QUAD



Four Beams. One Statement.

Designed to go beyond traditional single-lens projection, **MaxiGOBO Quad** introduces a new way to shape light, motion, and branding. With four independent gobos and a built-in 4-frame animation effect, it delivers layered visuals, dynamic movement, and striking impact from a single compact fixture.

Engineered for demanding indoor and outdoor installations, MaxiGOBO Quad combines a robust IP65 aluminium housing with precise optics and professional DMX control - making it ideal for architectural accents, immersive environments, themed attractions, and creative branding applications.

Whether operating in auto-run mode or fully integrated into a DMX system, MaxiGOBO Quad transforms façades, spaces, and surfaces into living visual elements.

One fixture. Multiple projections. Unlimited creativity.



MaxiGOBO QUAD

Specifications

Working Voltage : **AC110-240V**

Power : **320W**

Electrical Shock Protection : **Class I**

Control Protocol: **DMX512, Auto**

Light Source: **LED**

Color Temperature : **7500K**

Beam Angle : **10° / 20° / 30° / 45° / 60° / 70°**

Effect: **4 frames animations with 4 gobos**

Housing : **Aluminium**

Installation : **Bracket**

Weight : **10 kg**

IP Rated : **IP65**

Life: **> 40000 hrs**

Efficiency: **≥ 30lm/w**

Channels: **4**

Certification: **CE,ROHS**

Features



Finishes

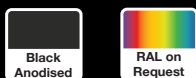

Dimensions (mm)

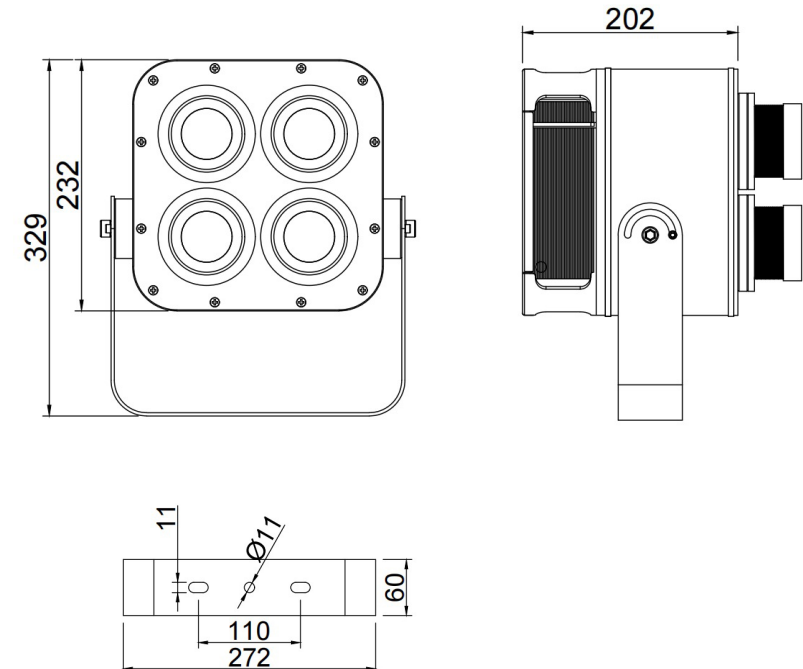

Gobos size (mm)

OD: 37.5

ID : 25

Thickness : 2.2

Certifications



MaxiLED
Lighting

MaxiGOBO QUAD



MaxiGOBO Projector

Unit 2, Farrington Place, Rossendale Road Ind. Est. Burnley, Lancashire. UK. BB11 5TY
T: +39 347 5911784 E: sales@maxigoboprojector.com Web: www.maxigoboprojector.com